

Customer :

# Specification for Approval

---

---

Part Name : **WM54T1F-xx75B**

Customer : \_\_\_\_\_ 2014. . . . .

Checked	Checked	Approved	Remark

WOOREE E&L Co., Ltd. 2014. 05. 12.

Designed	Checked	Checked	Approved
/	/	/	/

---

**WOOREE E&L CO., LTD** 636-3, Sunggok-dong, Danwon-gu, Ansan-si, Kyunggy-do, Korea.

Tel (031)599-3013 Fax (031)494-3174



# CONTENTS

1. Features
2. Outline Dimension
3. Absolute Maximum Ratings
4. Electrical / Optical Characteristics
5. Ranks
6. Color Spectrum
7. Characteristic Diagrams
8. Reliability
9. Recommend soldering conditions
10. Revision History

# 1. Features

- SMD Top View Type
- Long Time Reliability (with ESD Protection)
- Package size is 5.4 \* 5.0\* 0.8t (mm), 2Lead
- Application : General Lighting

# 2. Outline Dimension

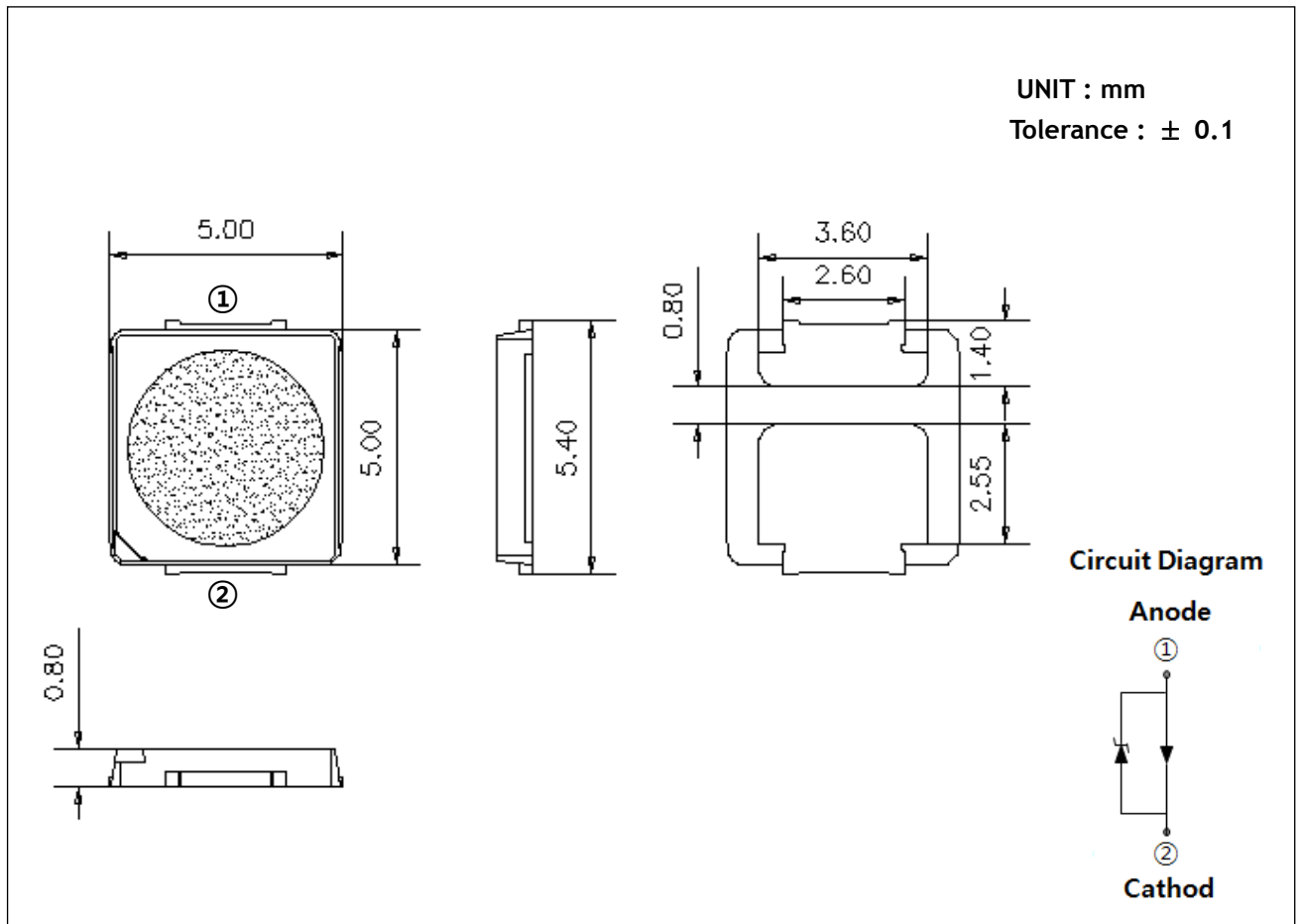

## Part list

Parts No.	Name	Description
1	Chip source	Blue LED
2	Body	Thermo Plastic
3	Lead frame base	Metal
4	Phosphor	R,G color Emitting
5	Resin	Encapsulant

### 3. Absolute maximum ratings

Item	Symbol	Absolute Maximum Ratings	Unit
Forward Current	$I_F$	120	mA
Pulse Forward Current*1	$I_{FP}$	200	mA
Reverse Current	$I_R$	50	mA
Power Dissipation	$P_D$	408	mW
Operating Temperature	$T_{OPR}$	-40 ~ +85	°C
Storage Temperature	$T_S$	-40 ~ +100	°C
Solder Temperature	$T_{SLD}$	Reflow 260 °C, 10sec under Hand 340 °C 3sec under	°C
Junction Temperature	$T_J$	110	°C

\*1. Pulse Width ≤ 10msec, Duty ≤ 10%

### 4. Electrical/Optical characteristics

(Ta=25 °C)

Item	Symbol	Condition	Value			Unit
			Min	Typ	Max	
Luminous Intensity *1	$I_v$	$I_F=60mA$	7.2	8.5	-	cd
Forward Voltage *2	$V_F$	$I_F=60mA$	2.85	3.05	3.25	V
Luminous Flux*3	$\Phi_V$	$I_F=60mA$	-	(28.5)	-	lm
Color Temperature *4 [CIE 1931 Coordinates]	CCT	$I_F=60mA$	4745	-	7690	K
Reverse Voltage	$V_R$	$I_R=5mA$	0.7	-	1.2	V
Viewing Angle	$2\theta_{1/2}$	$I_F=60mA$	-	120	-	Deg.
Color Rendering Index	Ra	$I_F=60mA$	75	-	-	-
Thermal Resistance	$R_{TH}$	$I_F=60mA$	-	24	-	°C/W

\*1. Luminous Intensity measurement allowance is ±10%

\*2. Forward voltage measurement allowance is ±0.1V

\*3. Reference data

\*4. CIE coordinates measurement allowance is ±0.005

## 5. Ranks

### (1) Forward Voltage

(Ta=25℃)

Rank	Condition	Min.	Max.	Unit
8	I <sub>F</sub> = 60mA	2.85	2.95	V
9		2.95	3.05	
0		3.05	3.15	
1		3.15	3.25	

### (2) Luminous Intensity

(Ta=25℃)

Rank	Condition	5000K	5700K	6500K	Unit
720	I <sub>F</sub> = 60mA	7.2-7.7	7.2-7.7	7.2-7.7	cd
770		7.7-8.2	7.7-8.2	7.7-8.2	
820		8.2-8.7	8.2-8.7	8.2-8.7	
870		8.7-9.2	8.7-9.2	8.7-9.2	
920		9.2-9.7	9.2-9.7	9.2-9.7	

\* Luminous Intensity Measuring condition is 0.01sr (CIE1931, LED Condition B)

(3) Chromaticity coordinates

( $I_f = 60\text{mA}$ ,  $T_a = 25^\circ\text{C}$ )

5000K ( CCT 5155 ~ 5311K )

50A		50B		50C		50D		50E	
x	y	x	y	x	y	x	y	x	y
0.3363	0.3307	0.3366	0.3369	0.3369	0.3431	0.3374	0.3554	0.3376	0.3616
0.3366	0.3369	0.3369	0.3431	0.3374	0.3554	0.3376	0.3616	0.3379	0.3678
0.3403	0.3398	0.3407	0.3462	0.3416	0.3589	0.3420	0.3652	0.3424	0.3716
0.3399	0.3335	0.3403	0.3398	0.3407	0.3462	0.3416	0.3589	0.3420	0.3652

5000K ( CCT 5010 ~ 5155K )

50F		50G		50H		50J		50K	
x	y	x	y	x	y	x	y	x	y
0.3399	0.3335	0.3403	0.3398	0.3407	0.3462	0.3416	0.3589	0.3420	0.3652
0.3403	0.3398	0.3407	0.3462	0.3416	0.3589	0.3420	0.3652	0.3424	0.3716
0.3441	0.3428	0.3446	0.3493	0.3458	0.3623	0.3463	0.3688	0.3469	0.3753
0.3435	0.3363	0.3441	0.3428	0.3446	0.3493	0.3458	0.3623	0.3463	0.3688

5000K ( CCT 4874 ~ 5010K )

50L		50M		50N		50O		50P	
x	y	x	y	x	y	x	y	x	y
0.3435	0.3363	0.3441	0.3428	0.3446	0.3493	0.3458	0.3623	0.3463	0.3688
0.3441	0.3428	0.3446	0.3493	0.3458	0.3623	0.3463	0.3688	0.3469	0.3753
0.3478	0.3457	0.3485	0.3524	0.3500	0.3658	0.3508	0.3724	0.3515	0.3791
0.3470	0.3391	0.3478	0.3457	0.3485	0.3524	0.3500	0.3658	0.3508	0.3724

5000K ( CCT 4745 ~ 4874K )

50Q		50R		50S		50T		50U	
x	y	x	y	x	y	x	y	x	y
0.3470	0.3391	0.3478	0.3457	0.3485	0.3524	0.3500	0.3658	0.3508	0.3724
0.3478	0.3457	0.3485	0.3524	0.3500	0.3658	0.3508	0.3724	0.3515	0.3791
0.3515	0.3487	0.3524	0.3555	0.3542	0.3692	0.3551	0.3760	0.3560	0.3828
0.3506	0.3419	0.3515	0.3487	0.3524	0.3555	0.3542	0.3692	0.3551	0.3760

5700K ( CCT 5823 ~ 6020K )

57A		57B		57C		57D		57E	
x	y	x	y	x	y	x	y	x	y
0.3226	0.3192	0.3222	0.3247	0.3218	0.3302	0.3210	0.3412	0.3206	0.3467
0.3222	0.3247	0.3218	0.3302	0.3210	0.3412	0.3206	0.3467	0.3202	0.3522
0.3258	0.3276	0.3256	0.3334	0.3251	0.3446	0.3249	0.3503	0.3247	0.3560
0.3260	0.3220	0.3258	0.3276	0.3256	0.3334	0.3251	0.3446	0.3249	0.3503

5700K ( CCT 5641 ~ 5823K )

57F		57G		57H		57J		57K	
x	y	x	y	x	y	x	y	x	y
0.3260	0.3220	0.3258	0.3276	0.3256	0.3334	0.3251	0.3446	0.3249	0.3503
0.3258	0.3276	0.3256	0.3334	0.3251	0.3446	0.3249	0.3503	0.3247	0.3560
0.3294	0.3307	0.3293	0.3364	0.3292	0.3482	0.3292	0.3540	0.3291	0.3599
0.3294	0.3248	0.3294	0.3307	0.3293	0.3364	0.3292	0.3482	0.3292	0.3540

5700K ( CCT 5468 ~ 5641K )

57L		57M		57N		57O		57P	
x	y	x	y	x	y	x	y	x	y
0.3294	0.3248	0.3294	0.3307	0.3293	0.3364	0.3292	0.3482	0.3292	0.3540
0.3294	0.3307	0.3293	0.3364	0.3292	0.3482	0.3292	0.3540	0.3291	0.3599
0.3330	0.3337	0.3331	0.3398	0.3333	0.3518	0.3334	0.3578	0.3335	0.3638
0.3329	0.3277	0.3330	0.3337	0.3331	0.3398	0.3333	0.3518	0.3334	0.3578

5700K ( CCT 5311 ~ 5468K )

57Q		57R		57S		57T		57U	
x	y	x	y	x	y	x	y	x	y
0.3329	0.3277	0.3330	0.3337	0.3331	0.3398	0.3333	0.3518	0.3334	0.3578
0.3330	0.3337	0.3331	0.3398	0.3333	0.3518	0.3334	0.3578	0.3335	0.3638
0.3366	0.3369	0.3369	0.3431	0.3374	0.3554	0.3376	0.3616	0.3379	0.3678
0.3363	0.3307	0.3366	0.3369	0.3369	0.3431	0.3374	0.3554	0.3376	0.3616

6500K ( CCT 6749 ~ 7040K )

65A		65B		65C		65D		65E	
x	y	x	y	x	y	x	y	x	y
0.3078	0.3066	0.3068	0.3113	0.3058	0.3160	0.3038	0.3256	0.3028	0.3304
0.3068	0.3113	0.3058	0.3160	0.3038	0.3256	0.3028	0.3304	0.3018	0.3351
0.3106	0.3150	0.3098	0.3199	0.3081	0.3299	0.3072	0.3348	0.3064	0.3397
0.3115	0.3101	0.3106	0.3150	0.3098	0.3199	0.3081	0.3299	0.3072	0.3348

6500K ( CCT 6485 ~ 6749K )

65F		65G		65H		65J		65K	
x	y	x	y	x	y	x	y	x	y
0.3115	0.3101	0.3106	0.3150	0.3098	0.3199	0.3081	0.3299	0.3072	0.3348
0.3106	0.3150	0.3098	0.3199	0.3081	0.3299	0.3072	0.3348	0.3064	0.3397
0.3145	0.3187	0.3138	0.3238	0.3123	0.3341	0.3116	0.3393	0.3109	0.3444
0.3152	0.3136	0.3145	0.3187	0.3138	0.3238	0.3123	0.3341	0.3116	0.3393

6500K ( CCT 6243 ~ 6485K )

65L		65M		65N		65O		65P	
x	y	x	y	x	y	x	y	x	y
0.3152	0.3136	0.3145	0.3187	0.3138	0.3238	0.3123	0.3341	0.3116	0.3393
0.3145	0.3187	0.3138	0.3238	0.3123	0.3341	0.3116	0.3393	0.3109	0.3444
0.3183	0.3224	0.3177	0.3277	0.3166	0.3384	0.3161	0.3437	0.3155	0.3490
0.3188	0.3171	0.3183	0.3224	0.3177	0.3277	0.3166	0.3384	0.3161	0.3437

6500K ( CCT 6020 ~ 6243K )

65Q		65R		65S		65T		65U	
x	y	x	y	x	y	x	y	x	y
0.3188	0.3171	0.3183	0.3224	0.3177	0.3277	0.3166	0.3384	0.3161	0.3437
0.3183	0.3224	0.3177	0.3277	0.3166	0.3384	0.3161	0.3437	0.3155	0.3490
0.3221	0.3261	0.3217	0.3316	0.3209	0.3426	0.3205	0.3481	0.3201	0.3536
0.3225	0.3206	0.3221	0.3261	0.3217	0.3316	0.3209	0.3426	0.3205	0.3481

7000K ( CCT 7349 ~ 7690K )

70A		70B		70C		70D		70E	
x	y	x	y	x	y	x	y	x	y
0.3010	0.2989	0.2997	0.3033	0.2984	0.3077	0.2958	0.3167	0.2945	0.3211
0.2997	0.3033	0.2984	0.3077	0.2958	0.3167	0.2945	0.3211	0.2931	0.3256
0.3032	0.3073	0.3021	0.3119	0.2998	0.3211	0.2986	0.3257	0.2975	0.3303
0.3044	0.3027	0.3032	0.3073	0.3021	0.3119	0.2998	0.3211	0.2986	0.3257

7000K ( CCT 7040 ~ 7349K )

70F		70G		70H		70J		70K	
x	y	x	y	x	y	x	y	x	y
0.3044	0.3027	0.3032	0.3073	0.3021	0.3119	0.2998	0.3211	0.2986	0.3257
0.3032	0.3073	0.3021	0.3119	0.2998	0.3211	0.2986	0.3257	0.2975	0.3303
0.3068	0.3113	0.3058	0.3160	0.3038	0.3256	0.3028	0.3304	0.3018	0.3351
0.3078	0.3066	0.3068	0.3113	0.3058	0.3160	0.3038	0.3256	0.3028	0.3304



(4) Chromaticity Coordinates Diagram

( $I_F = 60\text{mA}$ ,  $T_a = 25^\circ\text{C}$ )

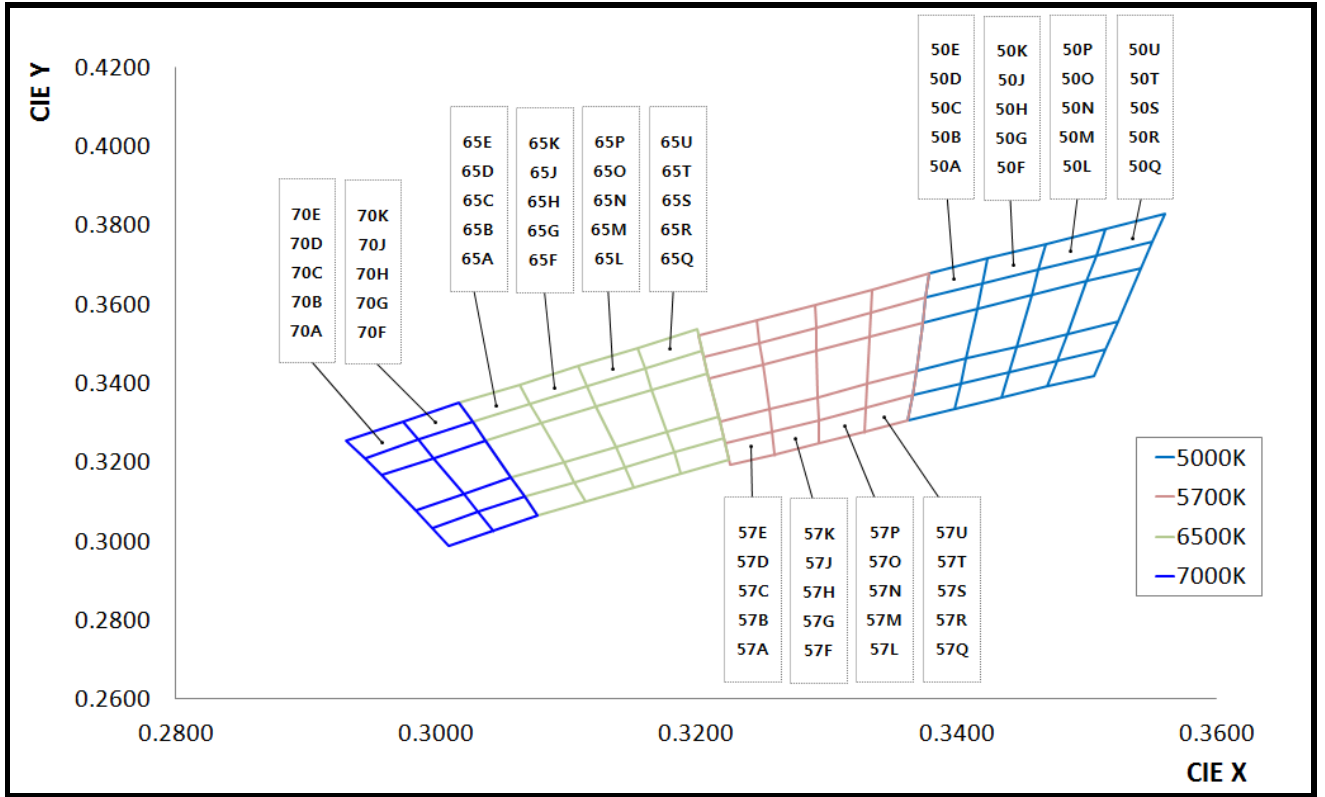

6. Color Spectrum

( $I_F = 60\text{mA}$ ,  $T_a = 25^\circ\text{C}$ )

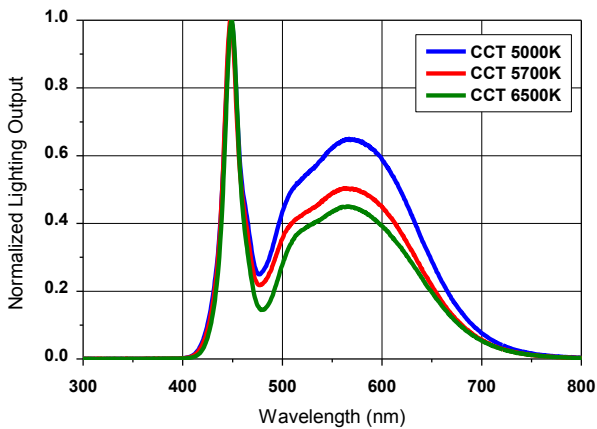

# 7.Characteristic Diagrams

(1) Forward Voltage vs Forward Current

(Ta = 25 °C)

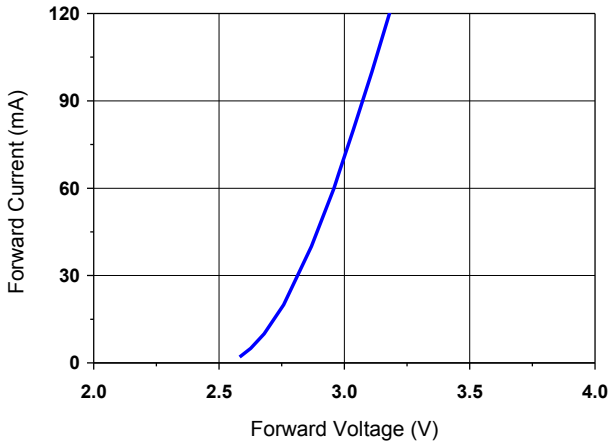

(2) Forward Current vs Relative L-Flux

(Ta = 25 °C)

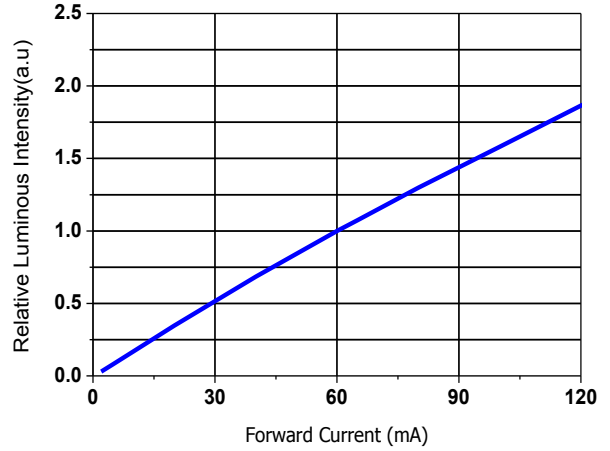

(3) Ambient Temperature vs Allowable Forward Current

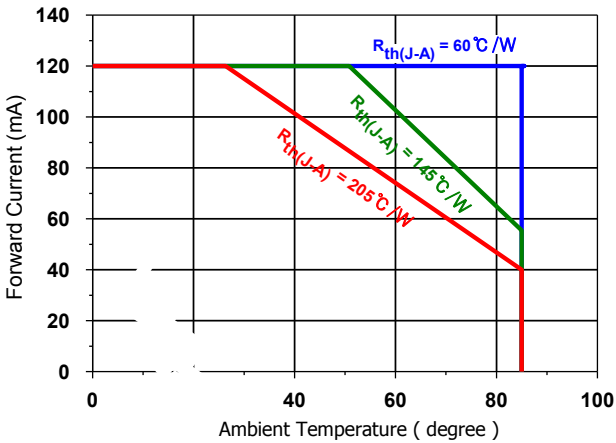

(4) Ambient Temperature vs Relative L-Flux

(If=60mA)

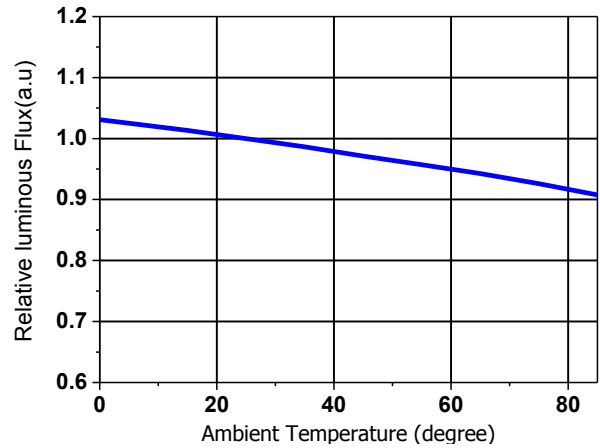

(5) View angle profile

(If=60mA, Ta=25 °C)

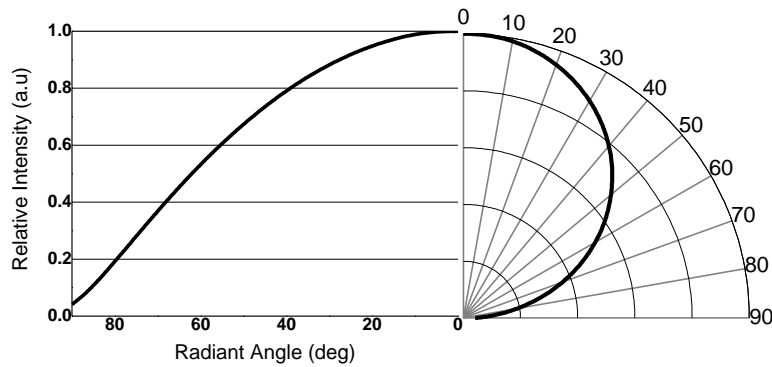

## 8. Reliability

### (1) Test items and results

NO	Test Item	Standard Test Method	Test Conditions	Note	Number of Damaged
1	Temperature Cycle	JEITA ED-4701 100 105	-40℃ ~ 25℃ ~ 100℃ ~ 25℃ 30min. 5min. 30min. 5min	100 cycles	0/20
2	High Temperature Storage	JEITA ED-4701 200 201	T <sub>A</sub> =85℃	1000 hrs	0/20
3	Temperature Humidity Storage	JEITA ED-4701 100 103	T <sub>A</sub> =85℃, RH=85%	1000 hrs	0/20
4	Low Temperature Storage	JEITA ED-4701 200 202	T <sub>A</sub> =-40℃	1000 hrs	0/20
5	Steady State Operating Life	-	T <sub>A</sub> =25℃, I <sub>F</sub> =75mA	1000 hrs	0/20
6	Steady State Operating Life of High Temperature <sup>2</sup>	-	T <sub>A</sub> =85℃, I <sub>F</sub> =75mA	1000 hrs	0/20
7	Steady State Operating Life of High Humidity Heat	-	T <sub>A</sub> =85℃, RH=85%, I <sub>F</sub> =75mA	1000 hrs	0/20
8	Steady State Operating Life of Low Temperature	-	T <sub>A</sub> =-40℃, I <sub>F</sub> =75mA	1000 hrs	0/20
9	Electro-Static Discharge Threshold	ESD (HBM)	1500Ω, 100pF (Forward / Reverse)	6000V	0/10

### (2) Criteria for judging the damage

ITEM	Symbol	Test Condition	Criteria for Judgement	
			Min.	Max.
Forward Voltage	V <sub>F</sub>	I <sub>F</sub> = 60mA	-	USL *1 × 1.2
Luminous Intensity	I <sub>V</sub>	I <sub>F</sub> = 60mA	LSL*2 × 0.7	

\*1) U.S.L. : Upper Standard Level    \*2) L.S.L : Lower Standard Level

## 9.Recommend soldering conditions

### (1) Recommend soldering conditions

Reflow Soldering		Hand Soldering(Lead Part)	
	Lead Free Solder		
Pre-heat Pre-heat time Peak temperature Soldering Time Condition	180~200℃ 120sec. Max. Max. 260℃ Max. 10sec	Temperature Soldering Time	Max. 340℃ Max. 3sec (only one time)

### Temperature-profile

#### <Lead-free Solder>

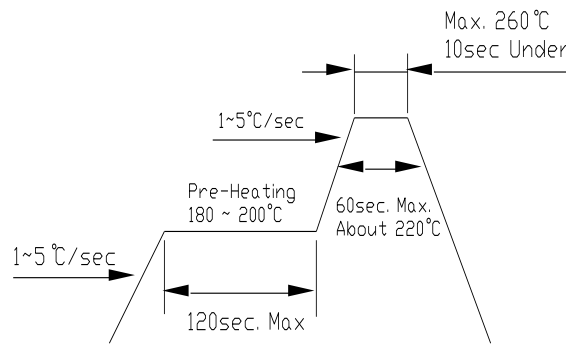

#### <Recommended soldering pad design>

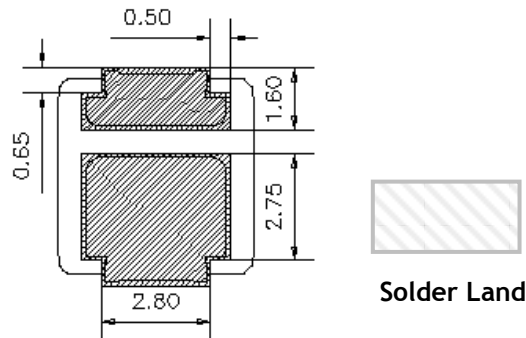

### (2)Moisture Proof Package

When moisture is absorbed into the SMT package it may vaporize and expand during soldering. There is a possibility that this can cause exfoliation of the contacts and damage to the optical characteristics of the LEDs. For this reason, the moisture proof package is used to keep moisture to a minimum in the package. The moisture proof package is made of an aluminum moisture proof bag. A package of a moisture absorbent material(silica gel) is inserted into the aluminum moisture proof bag. The silica gel changes its color from blue to pink as it absorbs moisture.

### **(3)Storage**

[Storage conditions]

Before opening the package

The LEDs should be kept at 30℃ or less and 90% RH or less. The LEDs should be used within a year. When storing the LEDs, moisture proof packaging with absorbent material(silica gel) is recommended.

After opening the package

The LEDs should be kept at 30℃ or less and 70% RH or less. The LEDs should be soldered within 168 hours(7days) after opening the package. If unused LEDs remain, they should be stored in moisture proof packages, such as sealed containers with package of moisture absorbent material(silica gel). It is also recommended to return the LEDs to the original moisture proof bag and to reseal the moisture proof bag again.

If the moisture absorbent material(silica gel) has faded away or the LEDs have exceeded the storage time, baking treatment should be performed using the following conditions.

Baking treatment : more than 24hours at 65±5℃

WOOREE E&L part's electrodes and lead frames are silver plated copper alloy.

The silver surface may be affected by environments which contain corrosive substances.

Please avoid conditions which may cause the LED to corrode, tarnish or discolor.

The corrosion or discoloration might lower solderability or might affect on optical Characteristics.

Please avoid rapid transitions in ambient temperature, especially in high humidity environments where condensation can occur.

### **(4)Heat Generation**

Thermal design of the end product is of paramount importance. Please consider the heat generation of the LED when making the system design. The coefficient of temperature increase per input electric power is affected by the thermal resistance of the circuit board and density of LED placement on the board, as well as other components. It is necessary to avoid intense heat generation and operate within the maximum ratings given in the specification.

The operating current should be decided after considering the ambient maximum temperature of LEDs.

# 10. Packing

## (1) Taping part

unit : mm  
tolerance : ± 0.1

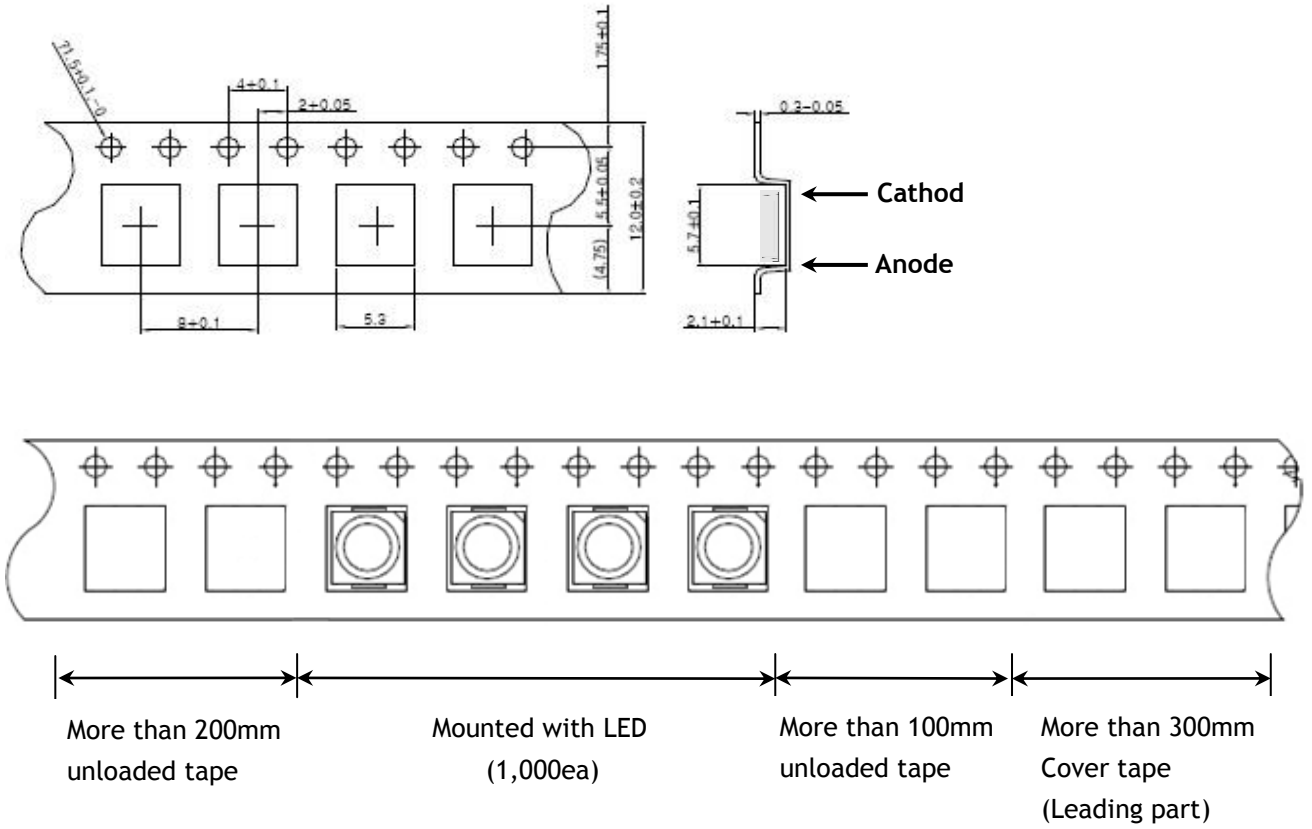

## (2) Reel part (Q'ty : 1,000ea/Reel)

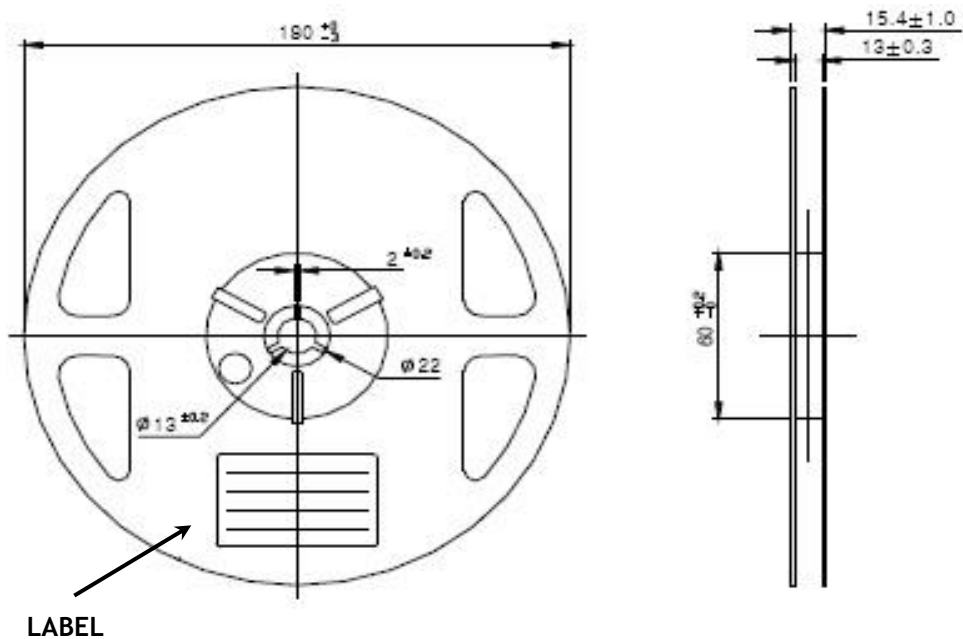

**(3) Boxing**

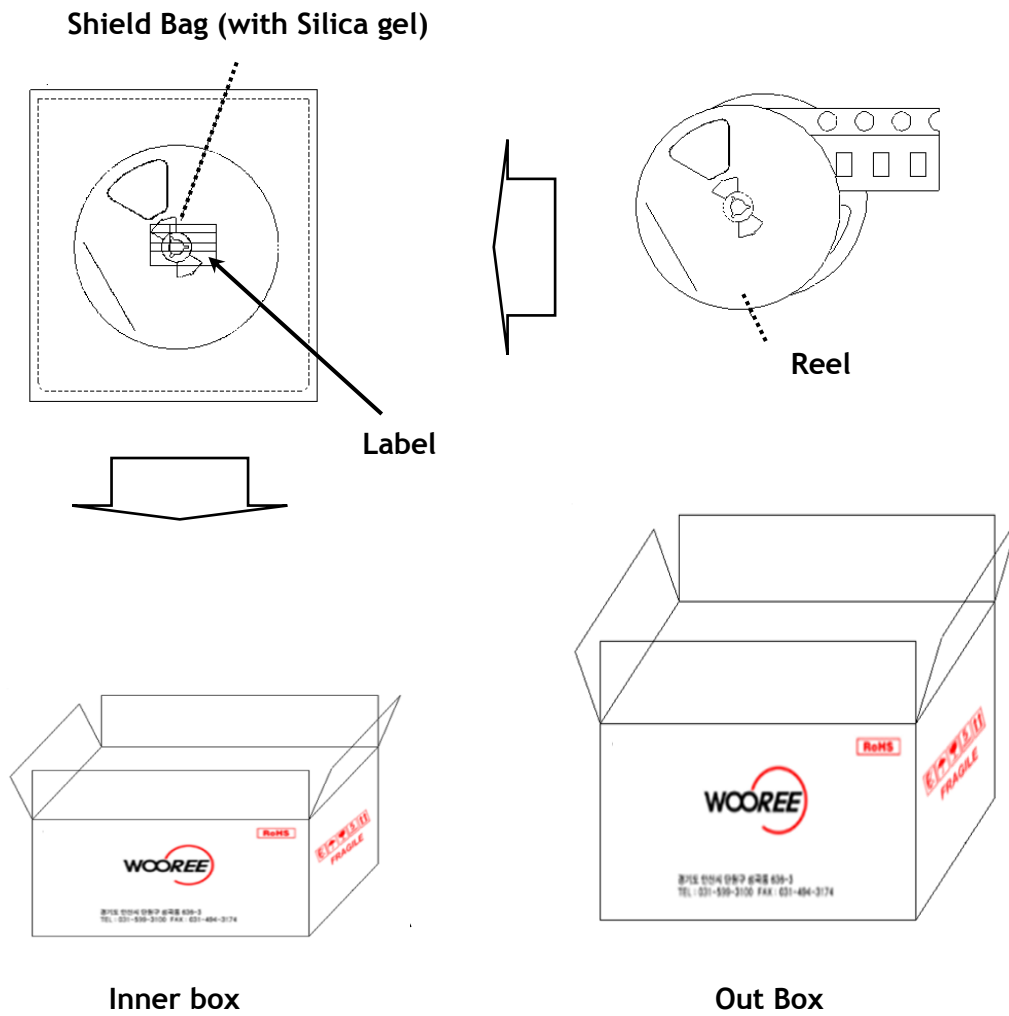

Box	Dimension (mm)	Reel/Box	Quantity/ Box
Inner box	500*260*250	30 Reel max.	30,000 ea
Out box	555*515*540	120 Reel max.	120,000 ea

(4) Label Information

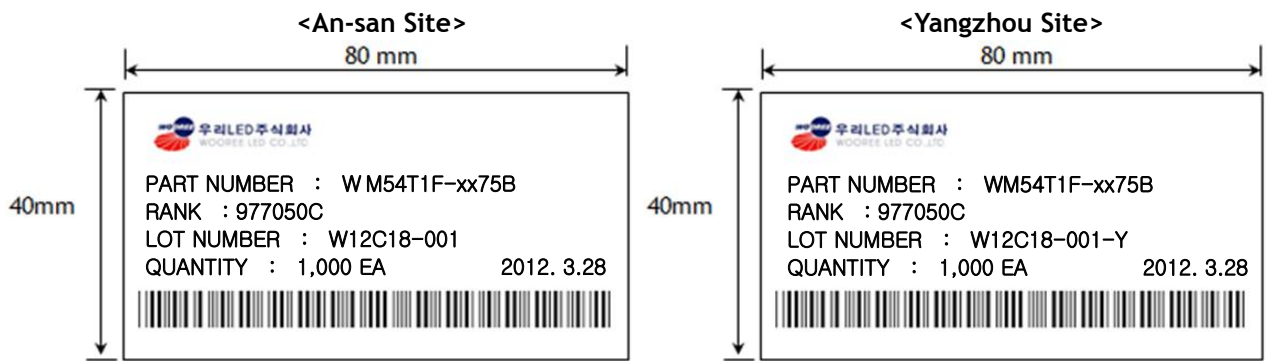

(5) Lot Number

<An-san Site>



- ① WOOREE E&L Initial
- ② Year (11 for 2011, 12 for 2012)
- ③ Month (A for Jan., B for Feb., ... , M for Dec.)
- ④ Day (01 for 1,....31 for 31)
- ⑤ WOOREE E&L Product Running Number

<Yangzhou Site>

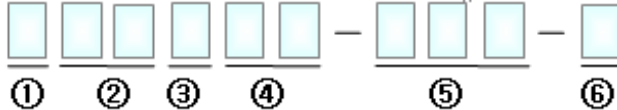

- ① WOOREE E&L Initial
- ② Year (11 for 2011, 12 for 2012)
- ③ Month (A for Jan., B for Feb., ... , M for Dec.)
- ④ Day (01 for 1,....31 for 31)
- ⑤ WOOREE E&L Product Running Number
- ⑥ WOOREE E&L Manufacturing Plant (Y for Yangzhou)

(6) Rank Code description

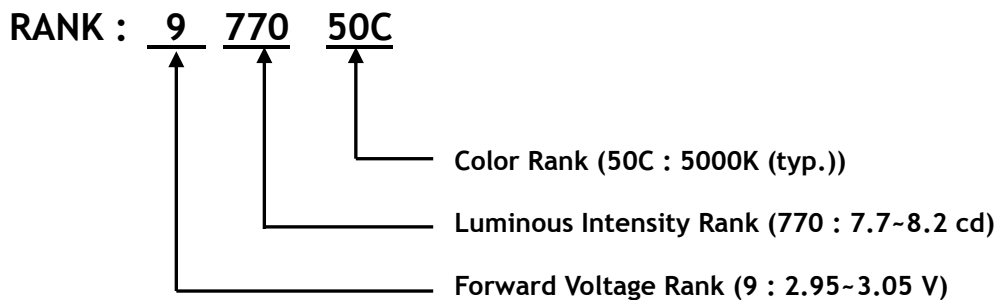



## 11. Revision History

Spec NO.			
Title	Specification for Approval		
Times	Date	Summary of revision	Remarks
1	2012. 05. 22	INITIAL ISSUE	R(0)
2	2012. 10. 24	Outline Dimension / Soldering pad design CIE Rank / T <sub>J</sub> & R <sub>TH</sub>	R(1)
3	2013. 03. 07	CCT 5700K Spec. addition	R(2)
4	2014. 05. 12	Luminous Intensity Rank addition	R(3)